

AZEK Rail should be installed using the same good building principals used to install wood or composite rail and in accordance with the local building codes and the installation guidelines included below. AZEK Building Products Inc. claims no liability or responsibility for the improper installation of this product. AZEK Rail may not be suitable for every application and it is the sole responsibility of the installer to be sure that AZEK Rail is fit for the intended use. Since all installations are unique, it is also the installer's responsibility to determine the specific requirements for each Rail application. AZEK Building Products recommends that all designs be reviewed by a licensed architect, engineer or local building official before installation. If you have any questions or need further assistance, please call AZEK Customer Service at 1-877-ASK-AZEK, (877) 275-2935 or visit our website at www.azek.com. **Please read all instructions completely before starting any part of the installation.** Each railing kit comes complete with all parts, hardware and installation guide to install one complete rail section (excluding posts.) Railing sections have been pre-cut to 6ft. or 8ft. lengths. Check to ensure that the kit is complete. **Safety:** Always wear goggles when handling, cutting, drilling and fastening materials. **Note:** Check local code requirements.

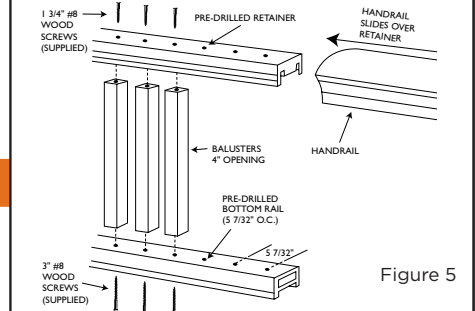
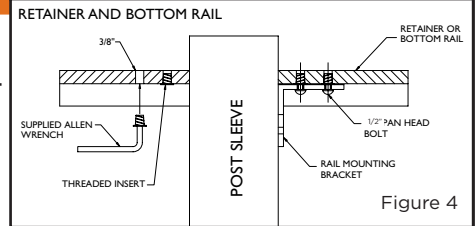
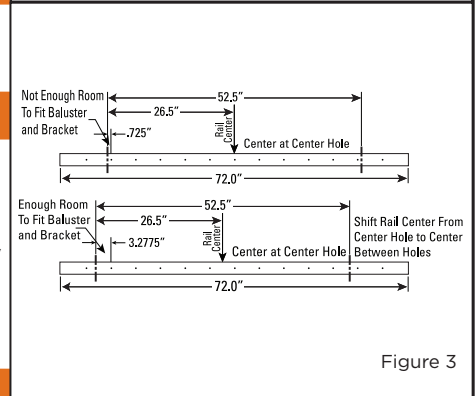
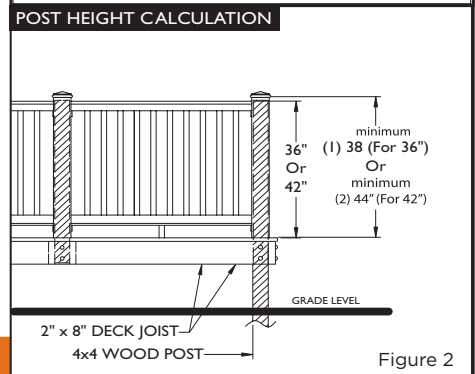
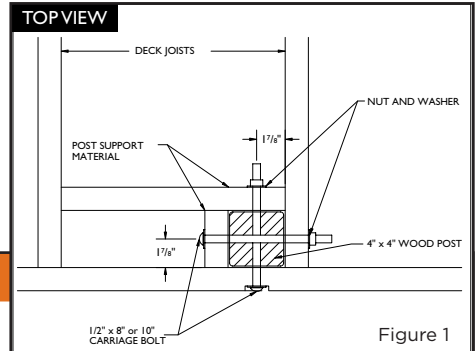

1. POST SLEEVE INSTALLATIONS

NOTE: POST SLEEVES ARE NOT DESIGNED TO BE USED IN STRUCTURAL APPLICATIONS. THEREFORE, THEY SHOULD NOT BE USED WHERE THEY MAY BE SUBJECT TO WEIGHT BEARING APPLICATIONS SUCH AS SUPPORTS FOR A ROOF OF A PORCH OR DECK. POST SLEEVES SHOULD NOT BE NOTCHED FOR INSTALLATION. The Post Sleeve has been designed to slide easily over a nominal wood 4" x 4" (min. 3 3/8" x 3 3/8", max. 3 9/16" x 3 9/16") post after the deck sub-structure is complete and the deck boards have been fastened. The 4" x 4" should extend down to the bottom of the rim joist and be completely "BOXED IN" around all 4 corners for the firmest attachment (see Figure 1). At this time, make sure the 4" x 4" wood posts are level and plumb to ease the installation of your railing system. If the nominal wood 4" x 4" post is twisted or oversized it will be necessary to shave the 4" x 4" wood post. Next, slide the Post Sleeve over the wood post (Do not force the Post Sleeve over the 4" x 4" as it may eventually lead to a crack or split). Post Sleeves may also be used over a wood post installed with a Surface Mount Bracket or over a Tallboy Surface Mount Bracket. For installation of a wood post to concrete, refer to the Surface Mount Bracket installation instructions or your local dealer. When using 6" x 6" post sleeves, a minimum 5 3/8" x 5 3/8" and a maximum 5 9/16" x 5 9/16" outside post dimension is required for a proper fit.

2. POST SLEEVE HEIGHT CALCULATIONS

Calculate and cut Post Sleeve to required height (see Figure 2). Slide Post Sleeve over 4" x 4" wood post into position. For 36" rail, cut Post Sleeve to a minimum of 38". For 42" rail, cut Post Sleeve to a minimum of 44".

3. POST SLEEVE MEASUREMENTS & CUTTING

Measure between posts, top and bottom to obtain the rail length. Also check the opening to ensure the Post Sleeves, newel posts or walls where the rail is to be installed are square and plumb. To obtain proper baluster spacing, measure half the determined rail length on the retainer/bottom rail from the center of the part. Note: This could be on a hole or from the center between holes only. If there is not enough room to fit the bracket and baluster side by side, alter the rail center from center hole to between holes or from between holes to center hole (this will move your baluster 2 5/8" either direction). Be sure not to allow any more than 4" between post sleeve and first baluster. If a rail must be cut so that the baluster sits on the bracket, the baluster end must be notched to fit around bracket and bracket bolt.

4. RETAINERS & BOTTOM RAIL BRACKET INSTALLATION

NOTE: THE DISTANCE BETWEEN THE BALUSTER AND THE POST SHOULD NOT EXCEED 4". MOST BUILDING CODES REQUIRE THAT A 4" SPHERE SHALL NOT PASS THROUGH THE RAIL AT ANY POINT. PLEASE NOTE THAT IT IS THE SOLE RESPONSIBILITY OF THE INSTALLER TO BE SURE THE AZEK RAIL MEETS THE LOCAL CODES AND IS APPLICABLE FOR EACH INSTALLATION.

To comply with the above statement, both top and bottom rails of 6ft sections, must be cut a minimum of 7/8" to allow no more than 4" spacing between the baluster and post. Place the "U" shaped end of the painted stainless steel bracket on the underside of the retainer and bottom rail. Be sure to place the bracket just slightly inside (1/16") the cut edge of the retainer and bottom rail. Mark and drill pilot holes with a 3/16" bit. Drill out the two mounting holes to 3/8". Note: When drilling for the bottom rail, drill through bottom wall only - do not drill through the top surface. Using the supplied 6mm Allen Wrench, screw the threaded inserts into the 3/8" holes from the bottom until flush. Be careful not to over torque. Next, fasten each bracket with (2) 1/4" x 20" panhead bolts to the underside of the retainer and bottom rail.

5. ASSEMBLE, FASTEN & SLIDE

Align the ends of each Baluster with the pre-drilled holes in the Retainer (see Figure 5). Using the 1 3/4" # 8 wood screws, fasten the Balusters to the Retainer first, through the pre-drilled holes. Do not over torque. Align the ends of the Balusters with the holes in the Bottom Rail and fasten the Balusters to the Bottom Rail through the pre-drilled holes using the 3" # 8 wood screws.

6. CENTER RAILING SUPPORT

Fasten center support in center of railing using 1" self-tapping screws. (see Figure 6a & b)
Check Chart 1 for the proper cut length for your style of rail. **Center support must be cut to meet local railing height requirements.**

CENTER SUPPORT SIZE		
CDN	Premier	2 ¹⁵ / ₁₆ "
CDN	Trademark	2 ⁵ / ₈ "
US	Premier	4 ⁵ / ₁₆ "

** indicates size supplied

CENTER SUPPORT SIZE		
US	Trademark	4 ⁵ / ₈ **
US	Reserve	4 ³ / ₈ "

** indicates size supplied

Chart 1

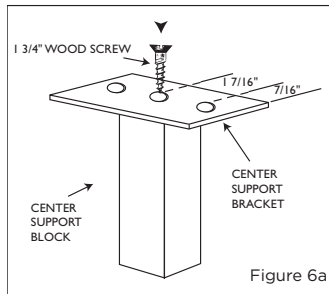

Figure 6a

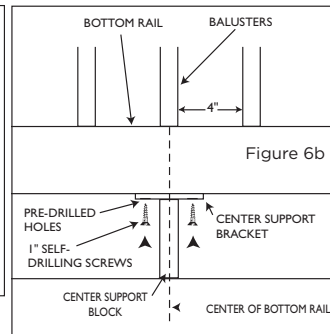

Figure 6b

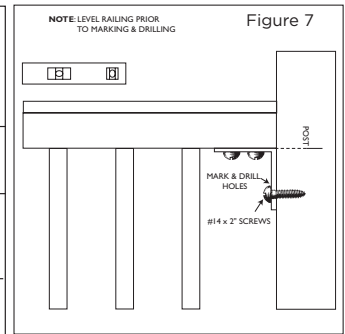

Figure 7

7. LEVEL & ATTACH RAILING

- Place assembled railing between Posts and level.
- Mark holes.
- Remove assembled railing.
- Drill pilot holes in the Posts with a 1/4" drill bit. (Be sure to only drill through post sleeve.)
- Re-position assembled railing.
- Fasten the section to the post using the 14 x 2" stainless steel painted screws supplied with a #3 square drive bit.
- When using Tallboy SMB be sure to use a 7/32" drill bit through post sleeve and SMB wall.

IMPORTANT: DO NOT OVER TORQUE SCREWS WHEN FASTENING RAIL TO POSTS AS THIS MAY CAUSE POST SLEEVES TO CRACK.

8. POST CAP APPLICATION

Apply generous amount of construction grade adhesive to top edges of Post Cap and press Post Cap firmly into place.

9. FASTEN HANDRAIL TO RETAINER

Take remaining self drilling screws that were used in Step 6 and install up through the retainer into the handrail to lock it in place. Space screws evenly over the span. **For care and cleaning instructions visit our website.**

RAILING CONVERSION FOR STAIRS

The assembly and installation of stair rail is the same as for horizontal rail (see over) except for changes detailed below. Please read instructions for horizontal rail before attempting to assemble and convert to stair rail.

1. PREPARATION

First check the rise and run of the stairs to determine the proper stair rail angle. (see Figure 8) Check the rail opening to ensure the sleeves, newels or walls where the stair rail is to be installed are square and plum. Measure between the Post Sleeves to obtain the rail length. Be sure to measure between the Post Sleeves at both top and bottom.

TIP: Ensure the proper fit by cutting a test piece of wood to the previously determined length and angle and fit it into the opening. Once the proper measurements have been confirmed, measure the handrail and retainer from the center of each part and trim an equal amount from each side to obtain the top length measured between the sleeves.

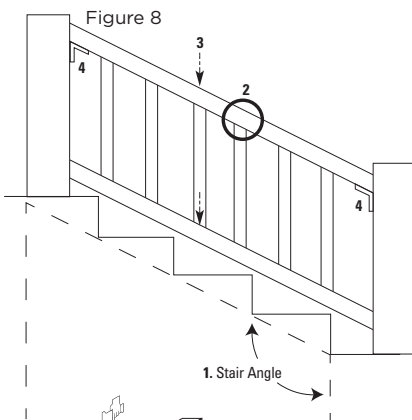

Figure 8

2. BALUSTERS Cut Balusters to proper angle, top and bottom. Keep length identical.

3. DRILLING HOLES RETAINER AND BOTTOM RAIL

The Retainer and Bottom Rail have been factory drilled for "horizontal" rail installations to assist with the assembly. For a stair rail installation, the Retainer and Bottom rail holes will need to be re-drilled to match the required stair rail angle. From the center of the top holes, draw a line the proper angle down the side of the bottom rail to be used as a guide (see Figure 9). Using a 3/16th bit, drill through the top hole following the angled guideline, and through the bottom of the rail making sure to drill through as close to the center line as possible.

TIP: Use a drill guide to ensure accuracy and see our website for additional information.

4. MOUNTING BRACKETS

Use the Stainless Steel Hinged Bracket included in the kit to fasten railing section to the posts. **IMPORTANT: DO NOT OVER TORQUE SCREWS WHEN FASTENING TO THE POSTS AS THIS MAY CAUSE THE POST SLEEVE TO CRACK.**

5. ASSEMBLE AND INSTALL

Assemble as per horizontal rail installation instructions Step #5.

Note: The 2 1/2" handrail is placed onto the retainer and secured using the self drilling screws supplied.

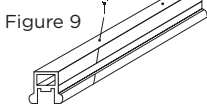

Figure 9

