

AZEK Rail should be installed using the same good building principals used to install wood or composite rail and in accordance with the local building codes and the installation guidelines included below. AZEK Building Products Inc. claims no liability or responsibility for the improper installation of this product. AZEK Rail may not be suitable for every application and it is the sole responsibility of the installer to be sure that AZEK Rail is fit for the intended use. Since all installations are unique, it is also the installer's responsibility to determine the specific requirements for each Rail application. AZEK Building Products recommends that all designs be reviewed by a licensed architect, engineer or local building official before installation. If you have any questions or need further assistance, please call AZEK Customer Service at 1-877-ASK-AZEK, (877) 275-2935 or visit our website at www.azek.com.

Read all instructions completely before starting any part of the installation. Each sub rail kit comes complete with all parts, hardware and installation guide to install one complete sub-rail kit. (EXCLUDING TOP RAIL, POSTS, SKIRTS AND CAPS) sub-rail kits have been pre-cut to 6' or 8' lengths. Check to ensure the kit is complete.

SAFETY: Always wear goggles when cutting, drilling, and fastening materials.

NOTE: Check local building code requirements prior to installation.

IMPORTANT NOTES

- 5 1/2" Top Rail is sold separately and comes in 6', 8', 12', and 16' lengths. Use the Top Rail Connectors with all joints including Post, In-Line, 45° and 22.5° to ensure a proper fit between parts.
- For best results, we recommend the use of the Tallboy Surface Mount Brackets for the most secure and strongest method of attachment.
- **Post sleeves are designed to be installed within the height of the rail system they are being used with and are NOT designed for structural use.**

1. POST INSTALLATIONS

NOTE: POST SLEEVES SHOULD NOT BE NOTCHED FOR INSTALLATION.

The 4" x 4" and 6" x 6" post sleeves have been designed to slide easily over the rust proof coated Tallboy. Follow the Surface Mount Bracket instructions for wood deck or concrete slab before installation of the Post Sleeves. Pressure treated wood 4" x 4" or 6" x 6" can also be used but is not recommended due to uncontrolled swelling, cracking and twisting of the wood. A minimum lumber size of 3 3/8" and a maximum of 3 9/16" is required for proper fit of sleeves. A tight fit is not recommended. When using 6" x 6" post sleeves, a minimum 5 3/8" x 5 3/8" and a maximum 5 9/16" x 5 9/16" outside post dimension is required for a proper fit.

IMPORTANT: DETERMINING POST HEIGHT

4" x 4" CENTER POST

For 36" railing height, the post sleeve must be cut to 34".

For 42" railing height, the post sleeve must be cut to 40".

6" x 6" MAIN POSTS

For other than column full height 6" x 6" post installations, cut the main 6" x 6" Post Sleeve a minimum of 2" higher than the desired rail height or 38" for a 36" rail or 44" for a 42" rail.

NOTE: If wood posts are being used, small shims may be used if excessive gaps are present in the post sleeves.



Figure 1

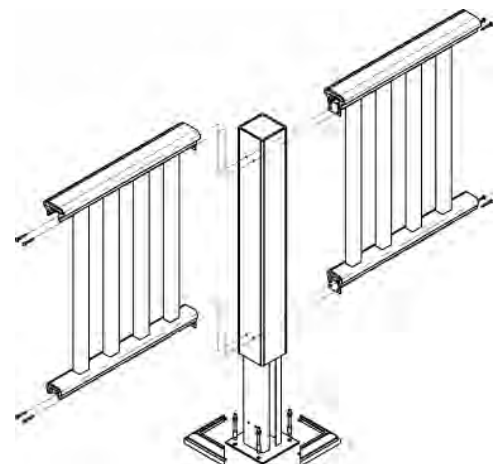

2. RAIL MEASURING AND CUTTING

Measure between post sleeves, top and bottom, to obtain the rail length. Also check rail opening to ensure the posts, newels or wall where the rail is to be mounted are plumb and square. To obtain proper baluster spacing, be sure to measure and cut retainer and bottom rail an equal distance from the center.

TIPS: See our website www.AZEK.com for:

- Optional cut technique to equally divide rail kits, i.e., make 2 rail sections from one rail kits.
- How to cut and position railing on the Post Sleeve at a 45° angle.

Figure 2

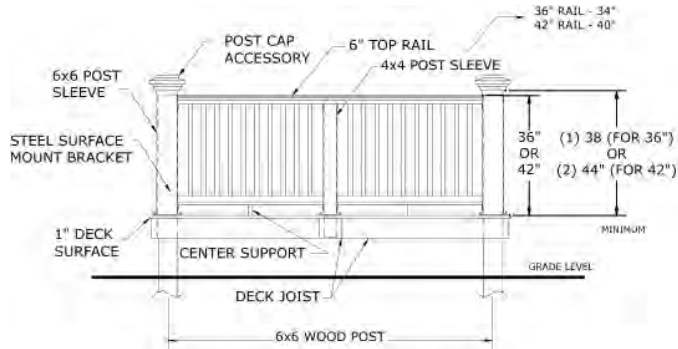

3. RETAINER & BOTTOM RAIL BRACKET INSTALLATION

Place the U shaped end of the bracket on the under side of the bottom rail and retainer just slightly inside (1/16") the cut edge. Mark and drill pilot holes with a 3/16" drill bit. Drill holes to proper size using a 3/8" drill bit.

NOTE: When drilling the bottom rail, drill through the bottom wall only - do not drill through the top surface wall. Using the Allen Key supplied, screw the threaded insert into the 3/8" holes from the bottom until flush. Be careful not to over tighten/torque. Fasten brackets using the 1/4" x 20" pan head bolts to the underside of the retainer and bottom rail.

NOTE: The hidden fastener brackets will not work in the over the post application for the Reserve Rail system due to the placement of the brackets.

Figure 3

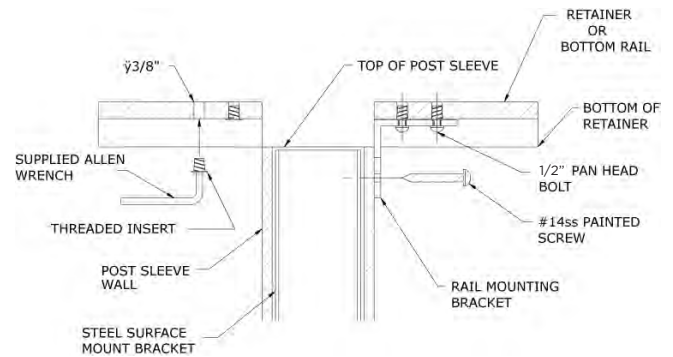

4. ASSEMBLE AND FASTEN

Align the ends of the baluster with the pre-drilled holes in the retainer (see figure 4). Using the #8 stainless steel wood screws, fasten the ends of the baluster to the retainer first, through the pre-drilled holes, then fasten the other ends of the balusters to the bottom rail (be careful not to overtighten/torque the screws.)

Figure 4

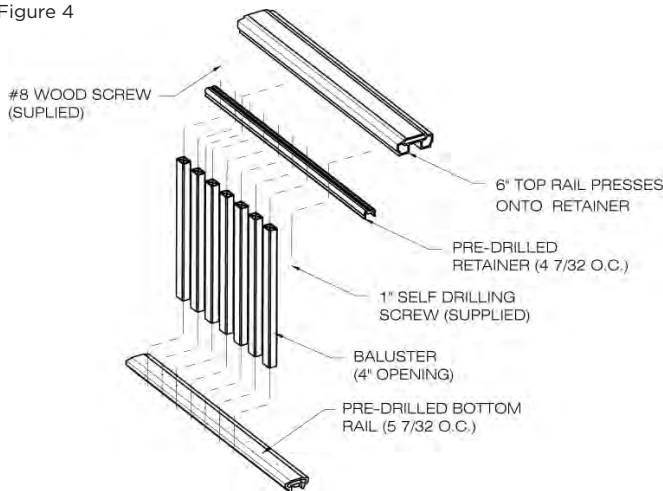

6. CONNECTION TO POSTS

4" x 4" Center Post, Corner Post and 6" x 6" Main Posts Center the assembled rail sub section between the post sleeves and position the bottom of the retainer approximately 1/16" above the top of the 4" x 4" center post. Mark the bracket hole locations and drill with a 1/4" drill bit.

Fasten the section to the post using the #14 x 2" stainless steel painted screws supplied with a #3 square drive bit.

NOTE: For the 4" x 4" center post and corner post, the bottom of the retainer should sit at the top of the post to allow the top hand rail to pass over the 4" x 4" center post.

For a center post corner application a 6" Top Rail Corner Connection Hardware Pack is required.

#6-1: 6" x 6" Main Posts, 45° Connection Follow the 45° Rail Installation Instructions or visit our website at www.AZEK.com for details. A 45° Hardware Pack is required for this installation.

NOTE: When fastening brackets to post sleeves DO NOT OVER TORQUE the screws. Once the screws are "seated" they are tight.

5. CENTER RAILING SUPPORT

Attach the stainless steel center support bracket to the pre-cut center support using the 1 remaining #8 wood screw. Install the support assembly in the center of the underside of the bottom rail using the 1" screws supplied in the sub kit.



7. INSTALL ALL SECTIONS

Before installing the top rail, ensure all sub rail sections are installed.



8. INSTALL 6" TOP HAND RAIL

After all sub rail sections have been installed, measure the length between the 6" x 6" main posts and cut the Top Rail.

(NOTE: Use the System Connectors, sold separately, at all joint connections to ensure proper fit). Place the cut Top Rail onto the retainer of the previously installed sub Rails and over the 4" x 4" center posts. (NOTE: If the top Rail is tight over the 4" x 4" Center Post, the retainers may be misaligned. To correct this problem, loosen the #14 x 2" stainless steel screws holding the top brackets, reinstall Top Rail and retighten the screws.)



#8-1: Install Corner 6" Top Rail over Center Post

Follow the directions as per step #8. Cut Top Rails with corresponding 45° angles approximately 1/8" shorter than a piece for a tight fit to allow room for the joiner piece. Before installation of the Top Rail, insert both Top Rails into the joiner.

Place the loose assembled Top Rail pieces onto the retainer, find the proper seating location and firmly press Top Rails onto the retainers.

(NOTE: Caulking may be used to seal the joiner to the Top Rail if desired.) A 4" x 4" Over-Post Connection Hardware Pack is required for this application.

9. FASTEN THE 6" TOP RAIL TO RETAINER

Use the remaining 1" stainless steel screws supplied, fasten up through the retainer into the underside of the Top Rail to lock it in place. Space screws evenly. For additional holding strength use caulking between the Retainer and the Top Rail.

Figure 5

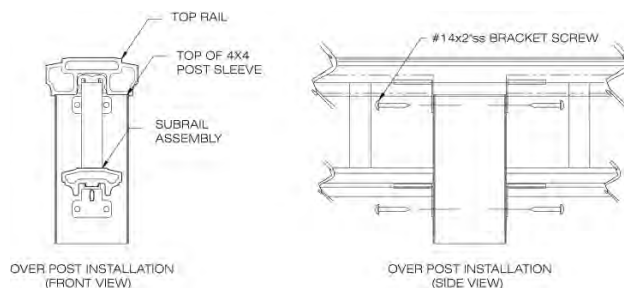

For additional information, visit WWW.AZEK.COM