

**AZEK<sup>®</sup> Trim is the #1 brand of trim.  
AZEK products are the perfect replacement for wood in  
all non-stress and non-load bearing applications.**

These guidelines cover the general installation recommendations for AZEK Trim and AZEK Moulding. See specific installation information for Universal Skirt Board, Integrated Drip Edge, Rabbeted Cornerboard, Finish Grade Trim, Water Table, and Garage Door Thermostop.

- AZEK Trim and AZEK Mouldings should be installed using the same good building principles used to install wood or composite trim and mouldings and in accordance with the local building codes and the installation guidelines included below. AZEK Building Products Inc. accepts no liability or responsibility for the improper installation of this product.
- AZEK Trim and AZEK Moulding may not be suitable for every application and it is the sole responsibility of the installer to be sure that AZEK Trim and Mouldings are fit for the intended use. Since all installations are unique, it is also the installer's responsibility to determine specific requirements in regards to each trim application.
- AZEK Building Products recommends that all applications be reviewed by a licensed architect, engineer or local building official before installation. If you have any questions or need further assistance, please call AZEK Customer Service at 877-ASK-AZEK (877-275-2935) or visit our website at [www.azek.com](http://www.azek.com).

## Storage & Handling

- Store AZEK Trim products on a flat and level surface.
- Since AZEK Trim products are more flexible than wood, they may conform to uneven surfaces. Ensure that storage areas, as well as all framing and substructures, are flat and level to minimize uneven surfaces.
- AZEK Trim products have a density comparable to pine and should be handled in a fashion as pine would be handled to avoid damage.
- Units of AZEK products are shipped from the manufacturer in a protective covering. If covering has been removed, take care to keep product free of dirt and debris at jobsite. If product gets dirty, clean after installation.

## Cutting

- AZEK products can be cut using the same tools used to cut lumber.
- Carbide tipped blades designed to cut wood work well. Avoid using fine tooth metal cutting blades.
- Rough edges from cutting may be caused by excessive friction, poor board support, or worn or improper tooling.

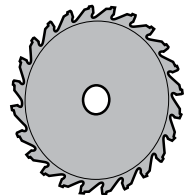

## Drilling

- AZEK products can be drilled using the same tools used to drill lumber.
- Drilling AZEK products is similar to drilling a hardwood. Care should be taken to avoid frictional heat build-up.
- Periodic removal of AZEK shavings from the drill hole may be necessary.



## Routing

- AZEK products can be routed using standard router bits and the same tools used to rout lumber.
- Carbide tipped router bits are recommended.
- Routing AZEK products provides a crisp, clean edge.

## Fastening

- For best results, use fasteners designed for wood trim and wood siding. These fasteners have a thinner shank, blunt point, and full round head.
- If desired, a #8 trim screw may be used and works well with AZEK Trim products.
- To take advantage of the performance of AZEK products, use a highly durable fastener such as stainless steel or hot dipped galvanized.
- Staples, small brads, and wire nails must not be used.
- The fasteners should be long enough to penetrate the solid wood substrate a minimum of 1 1/4".
- Standard nail guns work well with AZEK Trim products. If using pneumatic tools, the air pressure should be regulated so fasteners slightly penetrate the surface.
- Like wood, use 2 fasteners per every framing member for trimboard applications. Trimboards 12" or wider, as well as sheets, will require additional fasteners, not to exceed 8" on center. See illustration below.
- Fasteners must be installed within 2" of the end of each board. See illustration below.
- AZEK products should be fastened into a flat, solid substrate. Fastening AZEK material into hollow or uneven areas must be avoided.
- Pre-drilling is typically not required unless a large fastener is used or product is installed in low temperatures.
- 3/8" and 1/2" sheet product is not intended to be ripped into trim pieces. These profiles must be glued to a substrate and mechanically fastened.
- AZEK BEADBOARD FASTENING CONSIDERATIONS (Use one of the following):
  - #7 trim screw
  - 16 gauge T-nail
  - 15 gauge round head (for 1/2" Beadboard only)
  - Fasteners should be a minimum of 1 1/2" in length

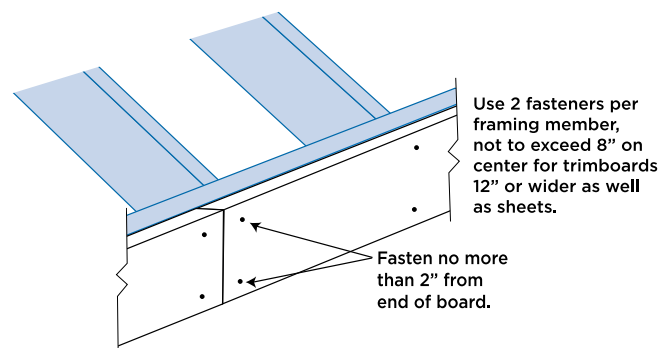

## Gluing

- For best results, glue all AZEK-to-AZEK joints such as window surrounds, long fascia runs, etc., with AZEK Adhesive to prevent joint separation.
- The glue joint should be secured with a fastener and/or fastened on each side of the joint to allow adequate bonding time.
- AZEK Adhesive has a working time of 10 minutes and will be fully cured in 24 hours.
- If standard pvc cements are used, these products typically cure quickly which will result in limited working time and may reduce adhesive strength.
- For best results, surfaces to be glued should be smooth, clean and in complete contact with each other.
- For best results, whenever possible, always use scarf joints instead of butt joints.
- To bond AZEK material to other substrates, various adhesive may be used. Consult adhesive manufacturer to determine suitability.

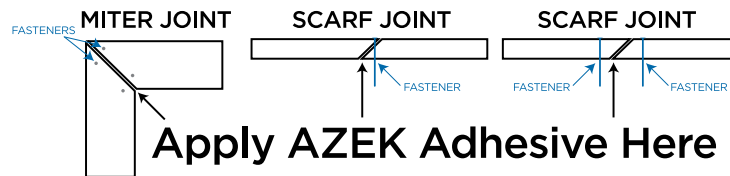

## Painting

- AZEK Trim does not require paint for protection, but accepts and holds paint very well.
- If you choose to paint, use a 100% acrylic latex paint with colors having a Light Reflective Value (LRV) of 55 or higher.
- For darker colors (LRV of 54 or lower), use paints specifically formulated for use on vinyl/pvc products such as, but not limited to, Sherwin-Williams VinylSafe® coatings. These paints/coatings are designed to reduce excessive heat gain.
- Follow the paint manufacturer's recommendations for use and compatibility with AZEK Trim and Mouldings.
- AZEK surfaces must be clean, dry, and void of any foreign material such as dirt, oil, grease or other contaminants that may come from normal handling, storage and/or installation prior to painting.
- Moisture cycling is a main reason for paint failure on wood. Since AZEK material absorbs no moisture, paints last longer on AZEK products than it does on wood.
- Since AZEK products have almost no moisture absorption, paints may take longer to cure on AZEK material than on wood. Generally paints on AZEK products will be dry to the touch quickly, but may take up to 30 days to fully cure depending on the humidity and temperature.
- **WARNING:** It is recommended that you only use standard VinylSafe® paint colors and do not request a custom blend from the paint manufacturer.



**100% Acrylic Latex  
with LRV 55 or higher.  
Use specifically  
formulated paints for  
darker colors  
(LRV 54 or lower).**

## Expansion & Contraction

- AZEK products expand and contract with changes in temperature.
- Properly fastening AZEK material along its entire length will minimize expansion and contraction.
- When properly fastened, allow 1/8" per 18 feet of AZEK product for expansion and contraction. Joints between pieces of AZEK material should be glued to eliminate joint separation. See "Gluing".
- When gaps are glued on a long run of AZEK material, allow expansion and contraction space at ends of the run.

## Spanning

- AZEK products must not be used in load bearing applications, but may be used in spanned applications such as fascias, soffits and ceilings. AZEK material should be installed over a solid backing.
- FOR SOFFIT INSTALLATIONS:
  - For spans greater than 16" OC, see below.
  - When using AZEK Beadboard, see considerations below.
- FOR CEILING INSTALLATIONS:
  - For spans greater than 16" OC, see below.
  - If temperature at time of installation is 40°F or below, spans need to be decreased to 12".
  - When using AZEK Beadboard, see consideration below.
- AZEK BEADBOARD SPANNING CONSIDERATION:
  - For both 1/2" and 5/8" AZEK Beadboard, run boards perpendicular to structure when possible to create the shortest possible run of material.
  - When using 1/2" AZEK Beadboard, use 12" OC framing as well as use a high quality construction grade polyurethane adhesive on joists.
    - For spans greater than 12" OC, use 5/8" AZEK Beadboard or use a minimum 1/2" backer such as plywood or OSB with construction grade adhesive and mechanical fastening a minimum of every 8". Fasteners should hit joist or framing when possible.
  - When using 5/8" AZEK Beadboard, use 16" OC framing as well as use a high quality construction grade polyurethane adhesive on joists. For spans greater than 16" OC, see below.
- For spans greater than 16" OC, use a minimum 1/2" backer such as plywood or OSB with construction grade adhesive and mechanical fastening a minimum of every 16". Fasteners should hit joist or framing when possible.
- Never span AZEK products more than 16" without utilizing instructions above. Proper fastening will help reduce the possibility of excessive movement from expansion and contraction.
- With all Beadboard or Trim ceiling and soffit installations, follow good building practices and ensure adequate ventilation is provided.

**AZEK<sup>®</sup> Trim is the #1 brand of trim.  
AZEK products are the perfect replacement for wood in  
all non-stress and non-load bearing applications.**

These guidelines cover the general installation recommendations for AZEK Trim and AZEK Moulding. See specific installation information for Universal Skirt Board, Integrated Drip Edge, Rabbeted Cornerboard, Finish Grade Trim, Water Table, and Garage Door Thermostop.

## Water Table

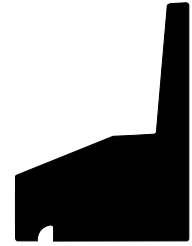
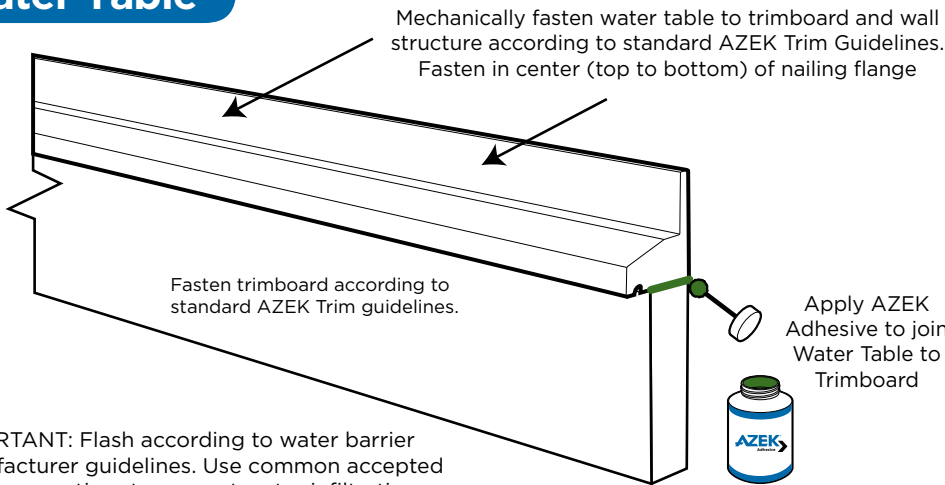

### SIZE

- 2 3/4" x 2" in 18' lengths
- 1 1/2" tapered starter strip/nailing flange height
- 3/8" thick starter strip/nailing flange (at its thickest point)

**IMPORTANT:** Flash according to water barrier manufacturer guidelines. Use common accepted building practices to prevent water infiltration.

## Garage Door Thermostop

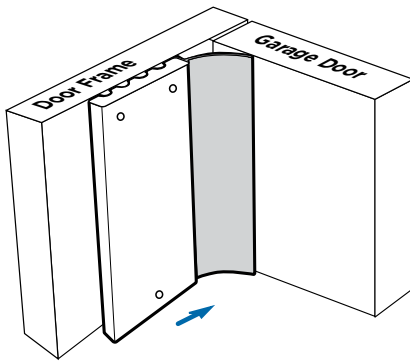

Firmly push Thermostop against Garage Door and fasten. Rubber seal should be in contact with Garage Door, but not overly tight. Place 2 fasteners within 1/2" of all ends and splices. All other fasteners should be 8" on center entire length of board.

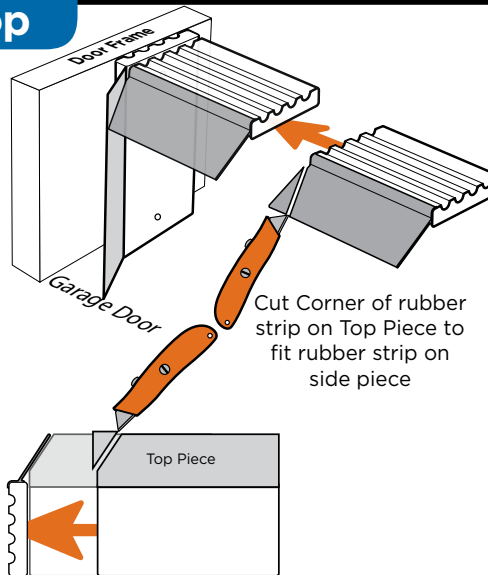

All AZEK to AZEK joints should be glued with AZEK Adhesive

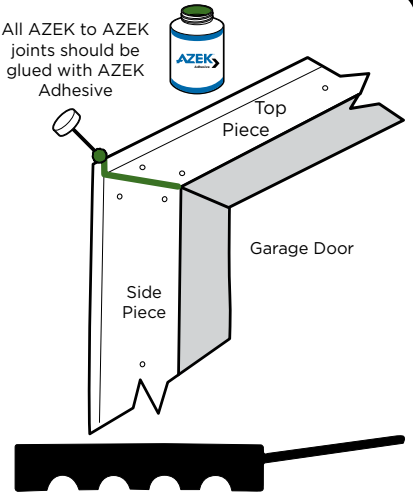

### SIZES

- 3/8" x 2"
- 7', 9', and 16' lengths

## Rabbeted Cornerboard

Leave gap to accommodate for siding according to manufacturer recommendations.

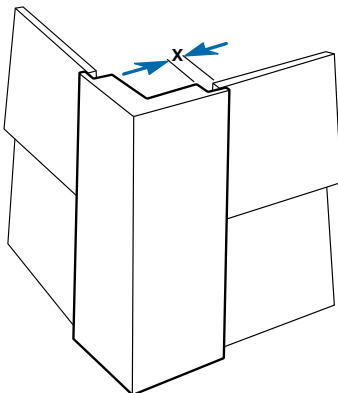

Fasten both sides according to standard AZEK Trim Guidelines. 4" Cornerboards may be installed using 2 fasteners at ends and splices and 1 fastener 12" OC through length of board.

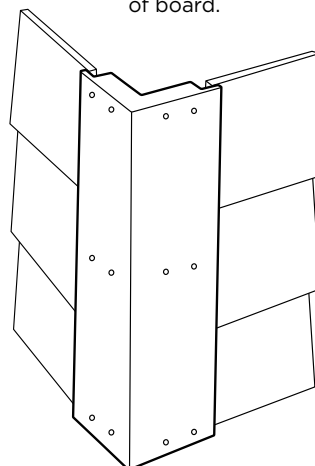

### SIZES

- 5/4 thick
- Traditional in 4", 6" and 8" widths
- Frontier in 4" and 6" widths
- 10' and 20' lengths

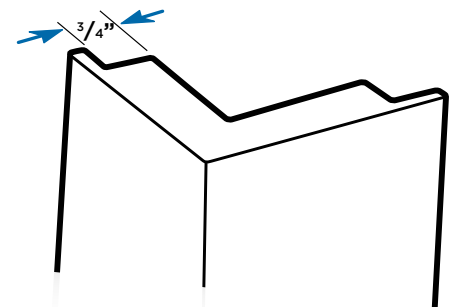

## Universal Skirt Board

This is a two part product. Choose trim finish by facing either Traditional or Frontier out. Insert Universal Skirt Board interface via press fit. Once inserted, USB interface cannot be removed.

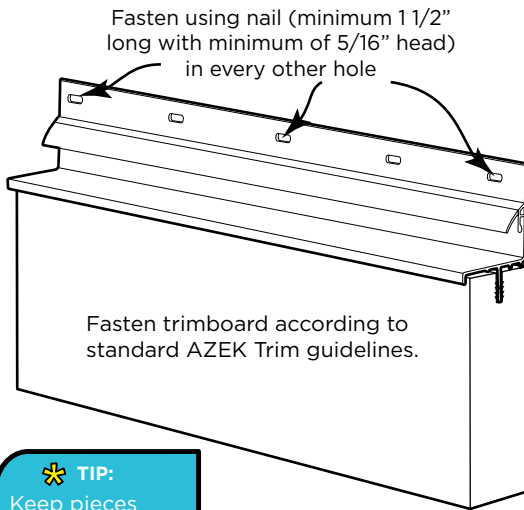

**\* TIP:**  
Keep pieces together while measuring and cutting for a more accurate fit

**IMPORTANT:** Flash according to water barrier manufacturer guidelines. Use common accepted building practices to prevent water infiltration.

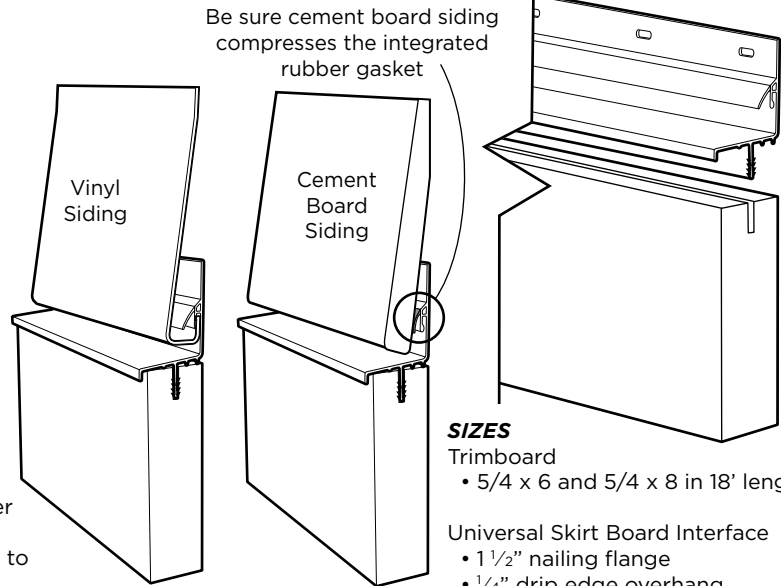

## Integrated Drip Edge

This is a two part product. Choose trim finish by facing either Traditional or Frontier out. Insert Integrated Drip Edge interface via press fit. Once inserted, IDE interface cannot be removed.

Fasten using nail (minimum 1 1/2" long with minimum of 5/16" head) in every other hole

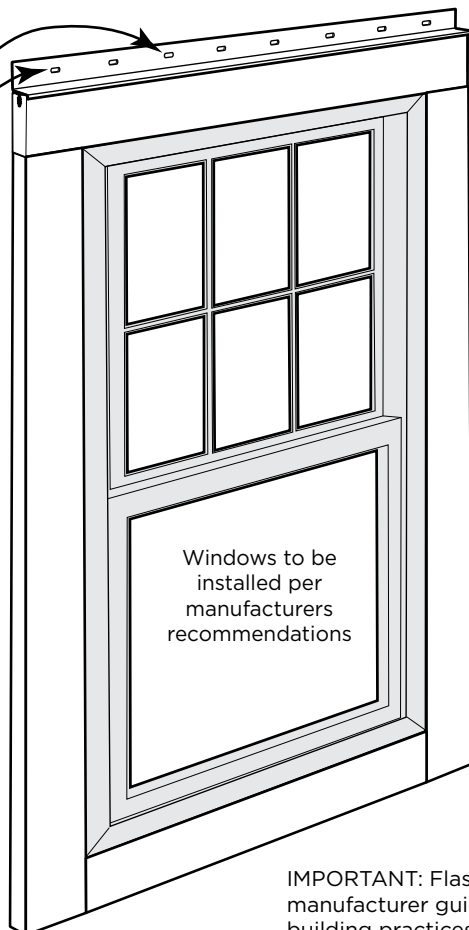

**IMPORTANT:** Flash according to water barrier manufacturer guidelines. Use common accepted building practices to prevent water infiltration.

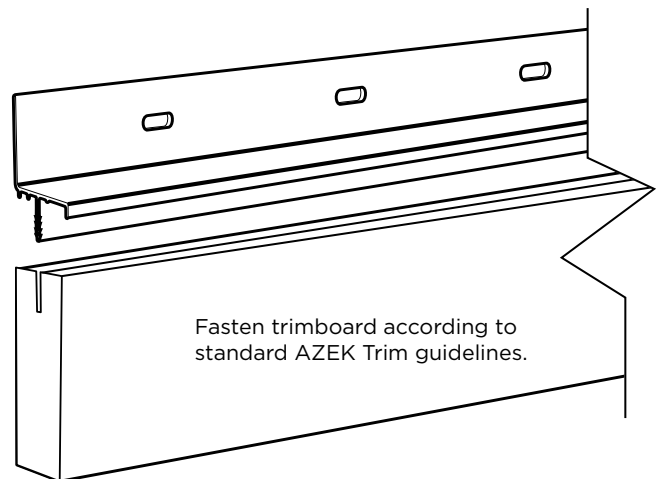

**SIZES**  
Trimboard  
• 5/4 x 4 and 5/4 x 6 in 18' lengths

Integrated Drip Edge Interface  
• 1 1/4" nailing flange  
• 1/8" drip edge overhang

**\* TIP:**  
Keep pieces together while measuring and cutting for a more accurate fit

## Finish Grade Trim

1

Measure and cut trim boards for mitered corners

**\* TIP:**

Keep pieces together while measuring and cutting for a more accurate fit

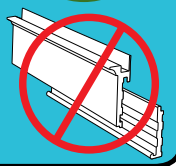
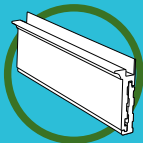

**\* TIP:**

For easier installation; first and last piece installed should be the shortest sections

Windows to be installed per manufacturers recommendations

This is a two part product.

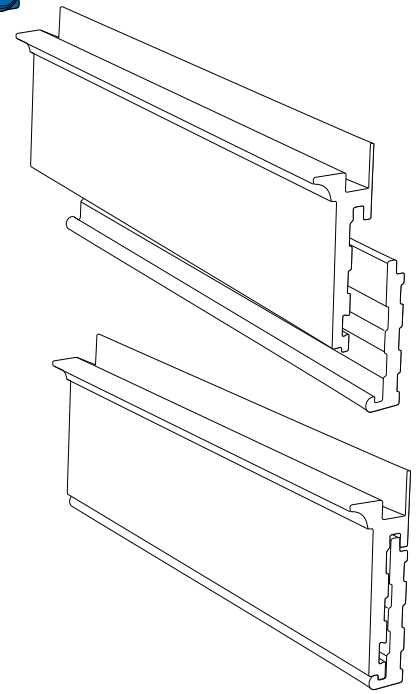

**SIZE**

- 6/4 x 6 in 18' lengths (approximate installed thickness and width)
- Traditional finish only

**IMPORTANT:** Flash according to water barrier manufacturer guidelines. Use common accepted building practices to prevent water infiltration.

2

Fasten according to standard AZEK Trim Guidelines

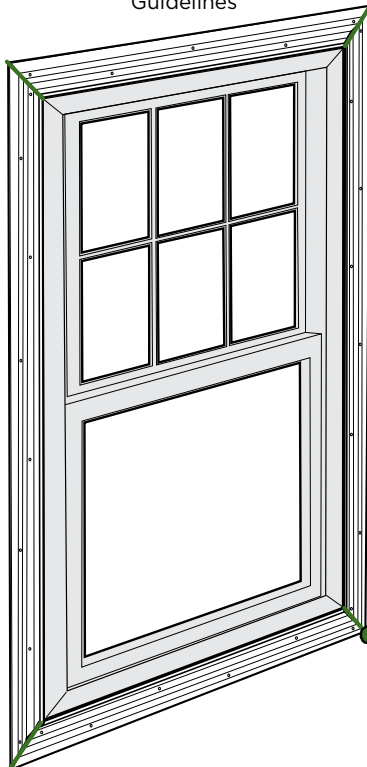

Glue all AZEK to AZEK joints

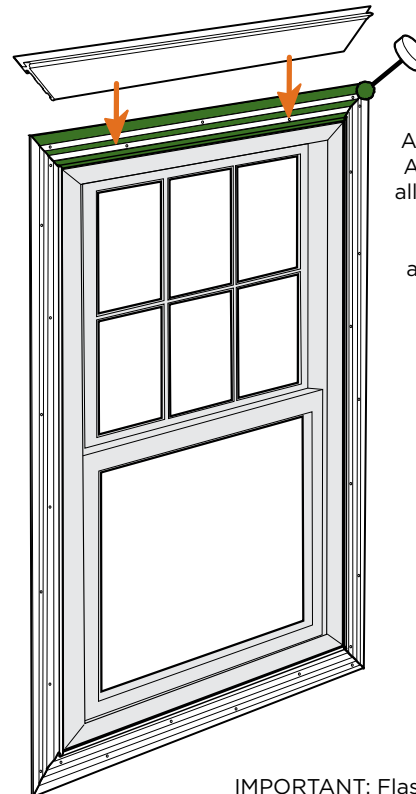

Apply AZEK Adhesive to all contacting surfaces before assembling cover

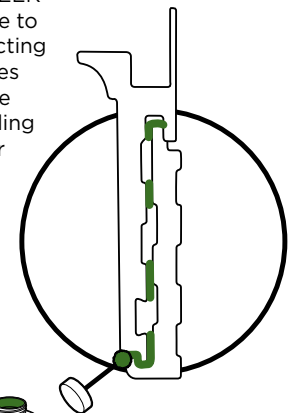

**IMPORTANT:** Flash according to water barrier manufacturer guidelines. Use common accepted building practices to prevent water infiltration.

**Finish Grade Trim**

**3**

Mechanically fasten through nailing flange using recommended AZEK Trim fastener

Apply AZEK Adhesive and insert corner reinforcements

As illustrated, apply AZEK Adhesive to base trim piece before installing Finish Grade Trim cover.

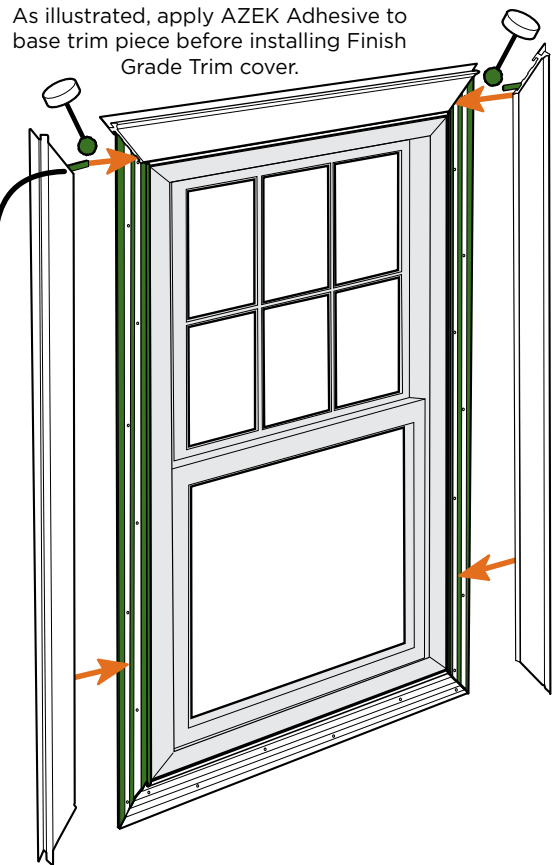
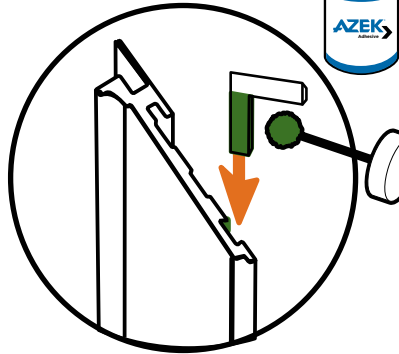
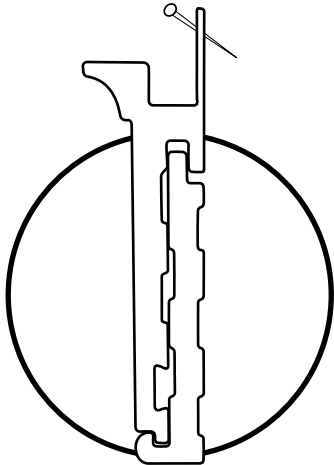

**4**

Tack covers at top to allow play at bottom for installing last piece

Apply AZEK Adhesive to corner joints

Glue all AZEK to AZEK joints with AZEK Adhesive

Apply AZEK Adhesive to corner joints

Complete the attachment of Finish Grade covers by mechanically fastening through nailing flange with recommended AZEK Trim fastener.

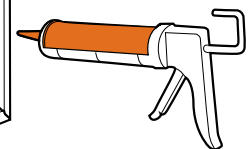
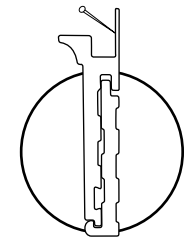

Caulk joint between window and trim to ensure proper seal

