

Installation Guidelines

Terra Collection Rim Joist Cover

For best results, install Terra Collection rim joist cover using the following guidelines:

RECOMMENDED FASTENERS

- > Stainless steel screws minimum #7 x 2" long should be used.

PREPARATION AND CONDITIONS

- > Store rim joist cover in a cooler, shady area prior to installation.
- > Store rim joist covers on a flat solid surface.

RIM JOIST COVER ATTACHMENT

- > Attach rim joist cover to a solid backer wide enough to support the entire width of the rim cover. Use 2 x 12 wood rim board or rip cut rim joist cover to fit exactly.
- > Use a quality exterior rated construction adhesive as shown below.
- > Install three screws from top to bottom with top and bottom screws positioned no more than 1/2" from the edge as shown below. The third screw should be approximately centered in the board. Repeat this configuration every 12". Screws at ends of boards should be no more than 1/2" from the end.

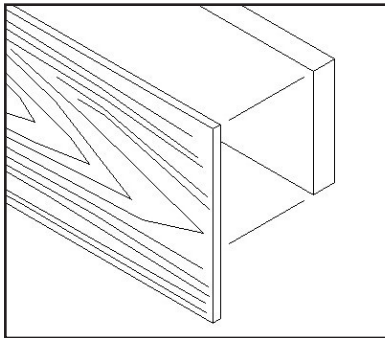

No!

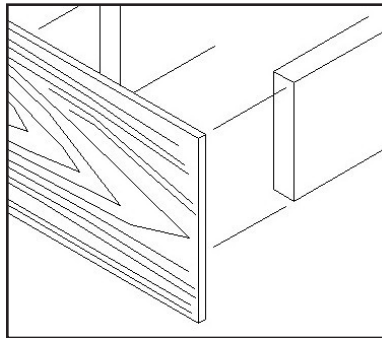

No!

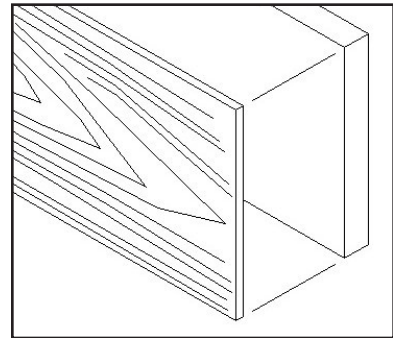

Correct!

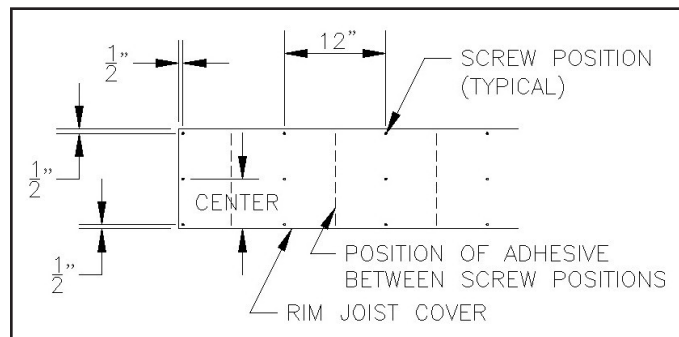
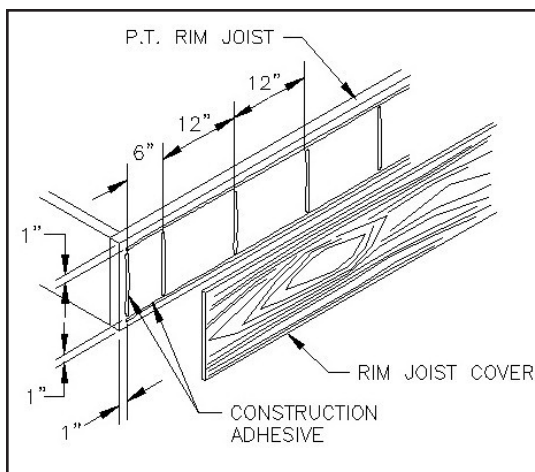

The techniques shown above should be used for best results. Results may vary as expansion and contraction could still occur. AZEK Building Products Inc. claims no liability or responsibility for the improper installation of this product. Since all installations are unique, it is the sole responsibility of the installer to determine specific requirements in regard to each decking application. AZEK Building Products recommends that all designs be reviewed by a licensed architect, engineer or local building official before installation. Please contact AZEK Customer Service prior to installing if you have question or concerns.