



Installation Guidelines for AZEK Trim and AZEK Moulding

STORAGE AND HANDLING

- Store AZEK Trim products on a flat and level surface.
- Since AZEK Trim products are more flexible than wood, they may conform to uneven surfaces. Ensure that storage areas, as well as all framing and substructures, are flat and level to minimize uneven surfaces.
- AZEK Trim products have a density comparable to pine and should be handled in a fashion as pine would be handled to avoid damage.
- Units of AZEK products are shipped from the manufacturer in a protective covering. If covering has been removed, take care to keep product free of dirt and debris at jobsite. If product gets dirty, clean after installation.

CUTTING

- AZEK products can be cut using the same tools used to cut lumber.
- Carbide tipped blades designed to cut wood work well. Avoid using fine tooth metal cutting blades.
- Rough edges from cutting may be caused by excessive friction, poor board support, or worn or improper tooling.

DRILLING

- AZEK products can be drilled using the same tools used to drill lumber.
- Drilling AZEK products is similar to drilling a hardwood. Care should be taken to avoid frictional heat build-up.
- Periodic removal of AZEK shavings from the drill hole may be necessary.

ROUTING

- AZEK products can be routed using standard router bits and the same tools used to rout lumber.
- Carbide tipped router bits are recommended.
- Routing AZEK products provides a crisp, clean edge.

AZEK® Trim is the #1 brand of trim. AZEK products are the perfect replacement for wood in all non-stress and non-load bearing applications.

FASTENING

- For best results, use fasteners designed for wood trim and wood siding. These fasteners have a thinner shank, blunt point, and full round head.
- If desired, a #8 trim screw may be used and works well with AZEK Trim products.
- To take advantage of the performance of AZEK products, use a highly durable fastener such as stainless steel or hot dipped galvanized.
- Staples, small brads, and wire nails must not be used.
- The fasteners should be long enough to penetrate the solid wood substrate a minimum of 1 1/4".
- Standard nail guns work well with AZEK Trim products. If using pneumatic tools, the air pressure should be regulated so fasteners slightly penetrates the surface.
- Like wood, use 2 fasteners per every framing member for trimboard applications. Trimboards 12" or wider, as well as sheets, will require additional fasteners, not to exceed 8" on center. See illustration below.
- Fasteners must be installed within 2" of the end of each board. See illustration below.
- AZEK products should be fastened into a flat, solid substrate. Fastening AZEK material into hollow or uneven areas must be avoided.
- Pre-drilling is typically not required unless a large fastener is used or product is installed in low temperatures.
- 3/8" and 1/2" sheet product is not intended to be ripped into trim pieces. These profiles must be glued to a substrate and mechanically fastened.
- AZEK BEADBOARD FASTENING CONSIDERATIONS (Use one of the following):
 - #7 trim screw
 - 16 gauge T-nail
 - 15 gauge round head (for 1/2" Beadboard only)
 - Fasteners should be a minimum of 1 1/2" in length

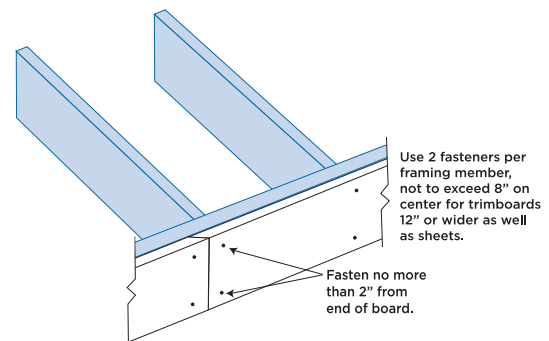

PAINTING

- AZEK Trim does not require paint for protection, but accepts and holds paint very well.
- If you choose to paint use a 100% acrylic latex paint with colors having a Light Reflective Value (LRV) of 55 or higher.
- For darker colors (LRV of 54 or lower), paints specifically designed for use on vinyl/pvc products such as, but not limited to, Sherwin-Williams VinylSafe™ coatings. These paints/coatings are designed to reduce excessive heat gain.
- Follow the paint manufacturer's recommendations for use and compatibility with AZEK Trim and Mouldings.
- AZEK surfaces must be clean, dry, and void of any foreign material such as dirt, oil, grease or other contaminants that may come from normal handling, storage and/or installation prior to painting.
- Moisture cycling is a main reason for paint failure on wood. Since AZEK material absorbs no moisture, paints last longer on AZEK products than it does on wood.
- Since AZEK products have almost no moisture absorption, paints may take longer to cure on AZEK material than on wood. Generally paints on AZEK products will be dry to the touch quickly, but may take up to 30 days to fully cure depending on the humidity and temperature.

GLUING

- For best results, glue all AZEK-to-AZEK joints such as window surrounds, long fascia runs, etc., with AZEK Adhesive to prevent joint separation.
- The glue joint should be secured with a fastener and/or fastened on each side of the joint to allow adequate bonding time.



- AZEK Adhesive has a working time of 10 minutes and will be fully cured in 24 hours.
- If standard pvc cements are used, these products typically cure quickly which will result in limited working time and may reduce adhesive strength.
- For best results, surfaces to be glued should be smooth, clean and in complete contact with each other.
- To bond AZEK material to other substrates, various adhesive may be used. Consult adhesive manufacturer to determine suitability.

EXPANSION & CONTRACTION

- AZEK products expand and contract with changes in temperature.
- Properly fastening AZEK material along its entire length will minimize expansion and contraction.
- When properly fastened, allow 1/8" per 18 feet of AZEK product for expansion and contraction. Joints between pieces of AZEK material should be glued to eliminate joint separation. See "Gluing".
- When gaps are glued on a long run of AZEK material, allow expansion and contraction space at ends of the run.

SPANNING

- AZEK products must not be used in load bearing applications, but may be used in spanned applications such as fascias, soffits and ceilings. AZEK material should be installed over a solid backing.
- FOR SOFFIT INSTALLATIONS:
 - When fastening over 16" OC, use a 5/4 AZEK product.
 - When using AZEK Beadboard, see considerations below.
- FOR CEILING INSTALLATIONS:
 - When fastening over 16" OC, use a 5/4 AZEK product.
 - If temperature at time of installation is 40° F or below, spans need to be decreased to 12".
 - When using AZEK Beadboard, see consideration below.
- AZEK BEADBOARD SPANNING CONSIDERATION:
 - For both 1/2" and 5/8" AZEK Beadboard, run boards perpendicular to structure when possible to create the shortest possible run of material.
 - When using 1/2" AZEK Beadboard, use 12" OC framing as well as use a high quality construction grade polyurethane adhesive on joists.
 - For spans greater than 12" OC, use 5/8" AZEK Beadboard or use a minimum 1/2" backer such as plywood or OSB with construction grade adhesive and mechanical fastening a minimum of every 8". Fasteners should hit joist or framing when possible.
 - When using 5/8" AZEK Beadboard, use 16" OC framing as well as use a high quality construction grade polyurethane adhesive on joists.
 - For spans greater than 16" OC, use a minimum 1/2" backer such as plywood or OSB with construction grade adhesive and mechanical fastening a minimum of every 16". Fasteners should hit joist or framing when possible.
- Never span AZEK products more than 16" without utilizing instructions above. Proper fastening will help reduce the possibility of excessive movement from expansion and contraction.
- With all Beadboard or Trim ceiling and soffit installations, follow good building practices and ensure adequate ventilation is provided.